

CAST-PAK

MODEL RD-1 CAST IRON DRAIN

The new Cast-Pak Assembly of the RD-1 Roof Drain provides the essential features of more expensive cast iron drains at an affordable price. It is adaptable to most generic materials of single ply and conventional built-up roofing for use with roof decks of steel, wood, precast concrete or gypsum. This drain offers versatility and easy installation on new and existing roofs. Available in sizes 3" (76 mm), 4" (102 mm), 6" (152 mm) and 8" (203 mm).

FEATURES:

- Molded polyethylene dome strainer. Bolts securely to clamping ring
- Epoxy coated cast iron body. No hub outlet
- Epoxy coated aluminum clamping ring with gravel stop. Grooved for positive drainage on smooth surfaced roofs. Distortion resistant and unbreakable.
- Aluminum underdeck clamp. Fastens drain securely to deck
- Fernco® flexible expansion coupling. Connects to PVC, ABS, or cast iron pipe.
- Overflow option available



TYPICAL 4" CAST-PAK DRAIN WITH FLEXIBLE EXPANSION COUPLING

WARNING
Cancer and Reproductive Harm
www.P65Warnings.ca.gov

PVC Coating Only

Cast-Pak Roof Drain kit are ideal for quick, simple drain installations in ponded roof areas and for many other applications where it is desirable to secure the drain to the roof deck construction.

The Cast Fast Pak allows for quick and easy installation from the deck, eliminating the need for underside installation via the underdeck clamp.

NEW CAST FAST PAK

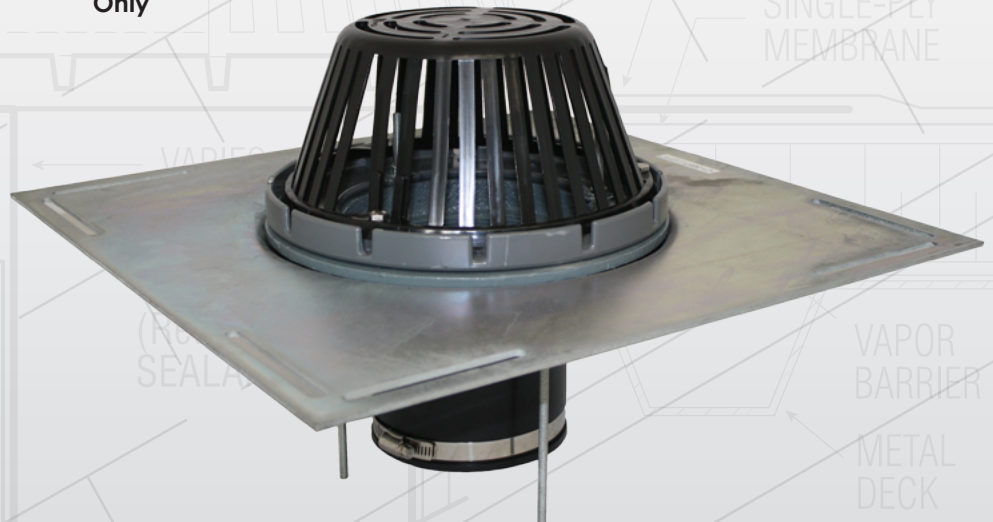

CAST-PAK

CAST-PAK INSTALLATION DETAILS FOR RE-ROOFING, ROOF-OVER & NEW ROOF CONSTRUCTION

INSTALLATION INFORMATION

ENPOCO-PAK INSTALLATION INFORMATION SHOULD BE READ BEFORE PROCEEDING TO INSTALL DRAIN.

1 FLASHING ATTACHMENT

Install single ply membrane, soft copper, lead or BUR felt flashing between clamping ring and drain flange.

2 COUPLING HOOK-UP

Will attach to Schedule 40 DWV plastic or no hub cast iron drain line.

3 ACCESSORY TIGHTENING PROCEDURE

Use a maximum of 60" lbs. of torque to tighten coupling bands and use care when securing clamping ring and underdeck clamp. Excessive tightening not required.

4 SPECIAL NOTE

Wet or damaged insulation or insulation with low compressive strength should be removed around drain flange seating area and replaced with insulation having a minimum compressive value of 25 PSI.

RD-1 SERIES DRAINS

- The large flat flange allows easy installation in any type of roof deck
- Cast Epoxy coated Elumaloy flashing clamp will not rust or fracture like cast iron clamps and will not distort like plastic clamps
- Options available to suit all standard installations

OPTIONS

- Under Deck Clamp
- Extension Flange
- Metal Dome
- Bearing Pan
- Waterproofing Flange
- Flotrol Device

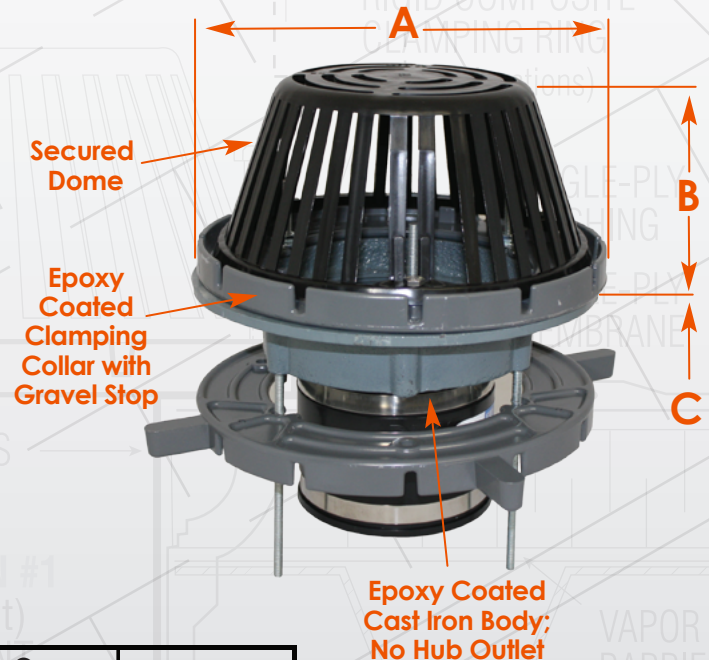
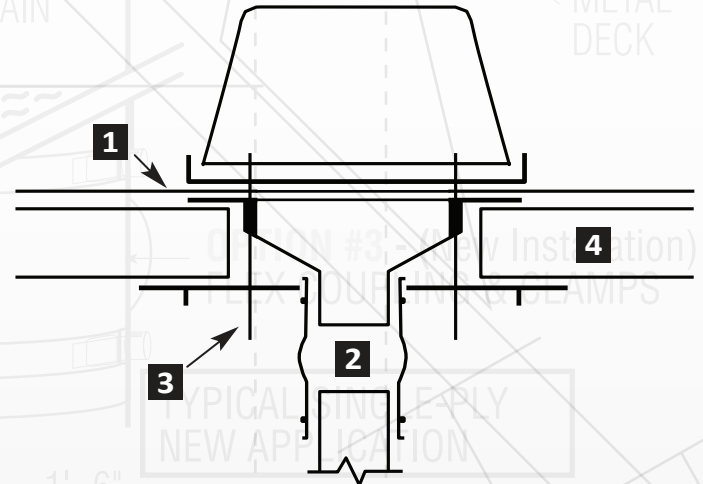

Drain Pipe Size	Option A	Option B	Option C	
3" 76mm, 4" 102mm	10.25" 260mm	5" 127mm	3.25" 83mm	
6" 152mm	15.625" 397mm	8" 204mm	5.5" 140mm	x 12" Strainer
8" 203mm	15.625" 397mm	8" 204mm	5.5" 140mm	x 12" Strainer